

V202312-EN

MiMA[®]
Min. Space Max. Performance

BANYITONG SCIENCE & TECHNOLOGY DEVELOPING CO.,LTD.

Since 1994

Electric Pallet Truck

ME20/25/30/40/60
MEB60

MiMA[®]
Min Space,Max Performance

ΕΠΙΚΟΙΝΩΗΣΤΕ ΜΑΖΙ ΜΑΣ

PEBRO - ΑΦΟΙ ΠΕΤΡΟΓΙΑΝΝΗ
Αγίας Σοφίας, Θέση Μιλιαδίστα Ασπρόπυργος,
19300, Αττική, Ελλάδα

Mail: info@pebro.gr Τηλέφωνο: +30 2105595360



Επίσημος εκπρόσωπος της
DEXION **SSI SCHAEFER**



ME20/25

Electric Pallet Truck(2t-2.5t)

MiMA ME20/25 series pallet truck is a flat point-to-point pallet truck. Bearing capacity range of 2-2.5 tons; the standard EPS makes the operation easier and safer. This truck is suitable for medium and long-distance horizontal transportation of medium and heavy-duty goods. It is widely used in logistics, warehousing, food, textile, printing, cold chain and other industries as well as medium and large shopping malls, supermarkets, freight yards, workshops and other occasions.



AC DRIVE SYSTEM

Maintenance-free high-power AC drive system provides reliable driving power; large-capacity battery provides strong endurance.

STAND-UP SHOCK-ABSORBING PLATFORM

Using an ergonomic shock-absorbing platform and a unique floating suspension system for stand-up driving, the driving wheels are always in contact with the ground, ensuring that the driving wheels have good grip and will not slip, while ensuring the forklift has excellent stability. Detachable pedal design makes it easier to replace parts.

SOLID BODY DESIGN

The vehicle body is specially designed with high obstacle surmounting ability and good passability; the five-point structure and the integrated shock absorption of the auxiliary wheels on both sides make the vehicle body highly stable and not easy to slip; the mechanical structure of the vehicle is made of solid materials, and key parts are made of high-strength steel plates, which is strong durable.

INTEGRATED HANDLE WITH PROTECTIVE ARMS

Integrated operating handle, emergency switch, folding protective arms, upper and lower brakes, belly switch, turning speed limit, undervoltage protection and other safety functions ensure driving safety. When the arm is lowered, the speed of the vehicle decreases by 30-40%, make the entire pallet truck safe, comfortable, labor-saving and flexible in operation.

DETAILS

- 1) With armrest safety function, when put down armrest, travelling speed will decrease by 30-40%, which increases safety of the operator.
- 2) Ergonomic shock-absorbing pedals.
- 3) Emergency reverse driving function to protect driver safety.
- 4) Emergency stop switch is used to quickly cut off the power supply in an emergency to ensure operator safety.
- 5) 5-pivots structure and balance wheel linkage system which improves the stability, adaptability and durability.
- 6) The mechanical material structure is solid, key parts are made of high-strength steel plates, which are sturdy and durable.



SPECIFICATION

Standard

1.1	Model	ME20	ME25	
1.2	Power type	Battery	Battery	
1.3	Operation	Stand on	Stand on	
1.4	Load capacity	Q(kg)	2000	2500
1.5	Load center distance	C(mm)	600	600
1.6	Front overhang	x(mm)	865	865
1.7	Wheelbase	y(mm)	1345	1345

Weights

2.1	Service weight (incl. battery)	kg	630	630
-----	--------------------------------	----	-----	-----

Wheels

3.1	Tyre type, front/rear	PU	PU	
3.2	Tyre size, front	mm	φ80×70	φ80×70
3.3	Tyre size, rear	mm	φ230×75	φ230×75
3.4	Caster wheel	mm	φ125×50	φ125×50
3.5	Wheels, number front/rear(X=driven)+caster wheel		4 / 1X+2	4 / 1X+2
3.6	Track width, rear	b10(mm)	476	476
3.7	Track width, front	b11(mm)	510	510

Dimensions

4.1	Overall height	h1(mm)	1430	1430
4.2	Fork lift height	h3(mm)	115	115
4.3	Lift height	h13+h3(mm)	200	200
4.4	Ground clearance, Min fork surface	h13(mm)	85	85
4.5	Pedal height	h4(mm)	155	155
4.6	Handle height	h5(mm)	1080~1340	1080~1340
4.7	Overall length, pedal off/on	l1(mm)	1900/2310	1900/2310
4.8	Overall width	b1(mm)	730	730
4.9	Fork outside spread	b2(mm)	680	680
4.10	Fork dimensions	l/e/s(mm)	1150/170/56	1150/170/56
4.11	Ground clearance, body	m2(mm)	35	35
4.12	Aisle width with pallet 1000*1200mm, C=500mm (with pedal folded)	Ast(mm)	2050/2500	2050/2500
4.13	Aisle width with pallet 800*1200mm, C=600mm (with pedal folded)	Ast(mm)	2100/2550	2100/2550
4.14	Turning radius(pedal folded/unfolded)	Wa(mm)	1730/2065	1730/2065

Performance

5.1	Travelling speed, laden/unladen	km/h	6/6	6/6
5.2	Lift speed, laden/unladen	mm/s	40/55	40/55
5.3	Lowering speed, laden/unladen	mm/s	35/35	35/35
5.4	Gradeability, laden/unladen(S2-5min)	%(tanθ)	6/15	6/15
5.5	Service brake		Electromagnetic	Electromagnetic

Driving

6.1	Drive motor rating (S2=60 min)	kw	1.5(AC)	1.5(AC)
6.2	Lift motor rating (S3=15%)	kw	2.2(DC)	2.2(DC)
6.3	Battery voltage/nominal capacity	V/Ah	24/210	24/210
6.4	Battery weight	kg	200	200
6.5	Steering system		EPS	EPS

Others

7.1	Battery replacement method		Hoisting	Hoisting
-----	----------------------------	--	----------	----------

Note:

1. The above table is the standard model data, which will be changed according to different configurations; model upgrade and optimization will also lead to changes in local structure and some dimensions

2. Optional configuration and non-standard customization:

- ① The length and width of the fork
- ② High-performance large battery capacity 270AH
- ③ Side-pull battery
- ④ Mechanical steering: ME20/25F08, without arms!

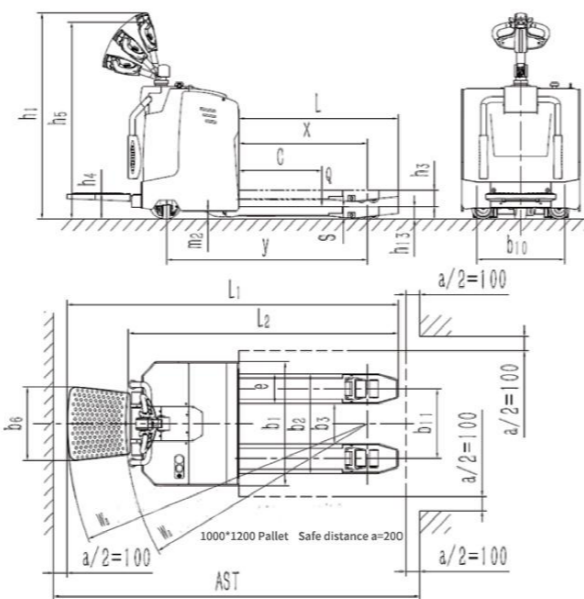

STANDARD & OPTIONAL

1150mm fork length	Customise fork length
PU wheel	Solid rubber tire for drive wheel
EPS steering	Mechanical steering
Lead acid battery	Lithium battery
With arms and platform	Side pull battery replacement
	Warning light
	Cold storage model
	Forks modified to platform
	Without arms and platform

ME30/40

Electric Pallet Truck(3t-4t)

The ME30/40 series truck is a flat pallet truck with a maximum load capacity of 4.0 tons.

It is suitable for horizontal transportation of heavy-duty goods over medium and long distances, such as loading, unloading and transporting palletized goods in warehouses, supermarkets and workshops.



STAND-UP SHOCK-ABSORBING PLATFORM

Using an ergonomic shock-absorbing platform and a unique floating suspension system for stand-up driving, the driving wheels are always in contact with the ground, ensuring that the driving wheels have good grip and will not slip, while ensuring the forklift has excellent stability. Detachable pedal design makes it easier to replace parts.

AC DRIVE SYSTEM

Maintenance-free high-power AC drive system provides reliable driving power; large-capacity battery provides strong endurance.

SOLID BODY DESIGN

The vehicle body is specially designed with high obstacle surmounting ability and good passability; the five-point structure and the integrated shock absorption of the auxiliary wheels on both sides make the vehicle body highly stable and not easy to slip; the mechanical structure of the vehicle is made of solid materials, and key parts are made of high-strength steel plates, which is strong durable.

INTEGRATED HANDLE WITH PROTECTIVE ARMS

Integrated operating handle, emergency switch, folding protective arms, upper and lower brakes, belly switch, turning speed limit, undervoltage protection and other safety functions ensure driving safety. When the arm is lowered, the speed of the vehicle decreases by 30-40%. Make the entire pallet truck safe, comfortable, labor-saving and flexible in operation.

DETAILS

- 1) With armrest safety function, when put down armrest, travelling speed will decrease by 30-40%, which increases safety of the operator.
- 2) Ergonomic shock-absorbing pedals.
- 3) Emergency reverse driving function to protect driver safety.
- 4) Emergency stop switch is used to quickly cut off the power supply in an emergency to ensure operator safety.
- 5) 5-pivots structure and balance wheel linkage system which improves the stability, adaptability and durability.
- 6) The mechanical material structure is solid, key parts are made of high-strength steel plates, which are sturdy and durable.



SPECIFICATION

Standard

1.1	Model		ME30	ME40
1.2	Power type		Battery	Battery
1.3	Operation		Stand on	Stand on
1.4	Load capacity	Q(kg)	3000	4000
1.5	Load center distance	C(mm)	600	600
1.6	Front overhang	x(mm)	985/910	930/855
1.7	Wheelbase	y(mm)	1515/1440	1460/1385

Weights

2.1	Service weight (incl. battery)	kg	810	950
2.2	Axle loading, laden rear/front	kg	1460/2400	1600/3300
2.3	Axle loading, unladen rear/front	kg	700/160	720/180

Wheels

3.1	Tyre type, front/rear		PU	PU
3.2	Tyre size, front	mm	φ80×70	φ80×110
3.3	Tyre size, rear	mm	φ230×75	φ230×75
3.4	Caster wheel	mm	φ150×50	φ150×50
3.5	Wheels, number front/rear(X=driven)+caster wheel		4 / 1X+2	4 / 1X+2
3.6	Track width, rear	b10(mm)	630	630
3.7	Track width, front	b11(mm)	510	480

Dimensions

4.1	Overall height	h1(mm)	1420	1420
4.2	Fork lift height	h2(mm)	110	115
4.3	Lift height		195	200
4.4	Ground clearance, Min fork surface	h3(mm)	85	85
4.5	Pedal height	h4(mm)	180	180
4.6	Handle height	h5(mm)	1090~1360	1090~1360
4.7	Overall length, pedal off/on	l1(mm)	1945/2390	1945/2390
4.8	Overall width	b1(mm)	850	850
4.9	Fork outside spread	b2(mm)	685	685
4.10	Fork dimensions	l/e/s(mm)	1150/175/75	1150/205/75
4.11	Ground clearance, body	m2(mm)	55	55
4.12	Aisle width with pallet 1000*1200mm, C=500mm (with pedal folded)	Ast(mm)	2150/2590	2150/2590
4.13	Aisle width with pallet 800*1200mm, C=600mm (with pedal folded)	Ast(mm)	2200/2640	2200/2640
4.14	Turning radius(pedal folded/unfolded)	Wa(mm)	1800/2220	1750/2170

Performance

5.1	Travelling speed, laden/unladen	km/h	5/6	5/6
5.2	Lift speed, laden/unladen	mm/s	29/33	23/33
5.3	Lowering speed, laden/unladen	mm/s	23/18	25/18
5.4	Gradeability, laden/unladen(S2-5min)	%(tanθ)	5/8	5/8
5.5	Service brake		Electromagnetic	Electromagnetic

Driving

6.1	Drive motor rating (S2=60 min)	kw	1.5(AC)	2.3(AC)
6.2	Lift motor rating (S3=15%)	kw	2.2(DC)	2.2(DC)
6.3	Battery voltage/nominal capacity	V/Ah	24/210	24/270
6.4	Battery weight	kg	200	240
6.5	Steering system		EPS	EPS

Others

7.1	Battery replacement method		Hoisting	Hoisting
-----	----------------------------	--	----------	----------

Note:

1. The above table is the standard model data, which will be changed according to different configurations; model upgrade and optimization will also lead to local structure and partial size changes;
2. Optional configuration and non-standard customization:
 - ① The length, width and outer distance of the fork;
 - ② Warp beam truck(fork and inclined plane);
 - ③ Side-pull batteries, batteries of different capacities;
 - ④ Mechanical steering product number: ME30F08, without arms;
 - ⑤ This model has no mechanical steering configuration.

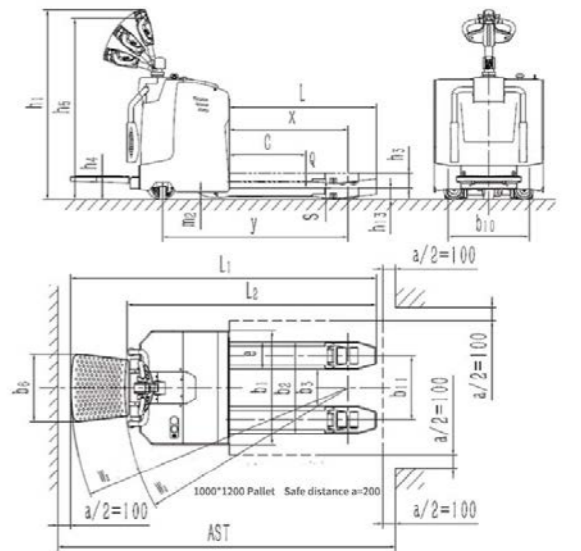

STANDARD & OPTIONAL

1150mm fork length	Customize fork length
PU wheel	Solid rubber tire for drive wheel
EPS steering	Mechanical steering
Lead acid battery	Lithium battery
With arms and platform	Side pull battery replacement
	Warning light
	Cold storage model
	Forks modified to platform
	Without arms and platform

ME60

Electric Pallet Truck(6t)

The ME60 series truck is a flat pallet truck with a maximum load capacity of 6.0 tons. Suitable for horizontal transportation of heavy-duty goods over medium and long distances, such as loading, unloading and handling palletized goods in warehouses, supermarkets, and workshops.



AC DRIVE SYSTEM

Maintenance-free high-power AC drive system provides reliable driving power large-capacity battery provides strong endurance.

STAND-UP SHOCK-ABSORBING PLATFORM

Using an ergonomic shock-absorbing platform and a unique floating suspension system for stand-up driving, the driving wheels are always in contact with the ground, ensuring that the driving wheels have good grip and will not slip, while ensuring the forklift has excellent stability. Detachable pedal design makes it easier to replace parts.

SOLID BODY DESIGN

The vehicle body is specially designed with high obstacle surmounting ability and good passability; the five-point structure and the integrated shock absorption of the auxiliary wheels on both sides make the vehicle body highly stable and not easy to slip; the mechanical structure of the vehicle is made of solid materials, and key parts are made of high-strength steel plates, which is strong durable.

INTEGRATED HANDLE WITH PROTECTIVE ARMS

Integrated operating handle, emergency switch, folding protective arms, upper and lower brakes, belly switch, turning speed limit, undervoltage protection and other safety functions ensure driving safety. When the arm is lowered, the speed of the vehicle decreases by 30-40%, Make the entire pallet truck safe, comfortable, labor-saving and flexible in operation.

DETAILS

- 1) With armrest safety function, when put down armrest, travelling speed will decrease by 30-40%, which increases safety of the operator.
- 2) Ergonomic shock-absorbing pedals.
- 3) Emergency reverse driving function to protect driver safety.
- 4) Emergency stop switch is used to quickly cut off the power supply in an emergency to ensure operator safety.
- 5) 5-pivots structure and balance wheel linkage system which improves the stability, adaptability and durability.
- 6) The mechanical material structure is solid, key parts are made of high-strength steel plates, which are sturdy and durable.



SPECIFICATION

Standard

1.1	Model		ME60
1.2	Power type		Battery
1.3	Operation		Stand on
1.4	Load capacity	Q(kg)	6000
1.5	Load center distance	C(mm)	600
1.6	Front overhang	x(mm)	980/935
1.7	Wheelbase	y(mm)	1525/1480

Weights

2.1	Service weight (incl. battery)	kg	1480
2.2	Axle loading, laden rear/front	kg	/
2.3	Axle loading, unladen rear/front	kg	/

Wheels

3.1	Tyre type, front/rear		PU
3.2	Tyre size, front	mm	φ90×80
3.3	Tyre size, rear	mm	φ254×100
3.4	Caster wheel	mm	φ125×50
3.5	Wheels, number front/rear(X=driven)+caster wheel		8/1X+4
3.6	Track width, rear	b10(mm)	630
3.7	Track width, front	b11(mm)	460

Dimensions

4.1	Overall height	h1(mm)	1420
4.2	Fork lift height	h2(mm)	110
4.3	Lift height		205
4.4	Ground clearance, Min fork surface	h3(mm)	95
4.5	Pedal height	h4(mm)	180
4.6	Handle height	h5(mm)	1090~1360
4.7	Overall length, pedal off/on	l1(mm)	1945/2390
4.8	Overall width	b1(mm)	850
4.9	Fork outside spread	b2(mm)	715
4.10	Fork dimensions	l/e/s(mm)	1200/255/87
4.11	Ground clearance, body	m2(mm)	55
4.12	Aisle width with pallet 1000×1200mm, C=500mm (with pedal folded)	Ast(mm)	2250/2690
4.13	Aisle width with pallet 800×1200mm, C=600mm (with pedal folded)	Ast(mm)	2300/2740
4.14	Turning radius(pedal folded/unfolded)	Wa(mm)	1900/2320

Performance

5.1	Travelling speed, laden/unladen	km/h	4.0/4.5
5.2	Lift speed, laden/unladen	mm/s	29/35
5.3	Lowering speed, laden/unladen	mm/s	29/16
5.4	Gradeability, laden/unladen(S2-5min)	%(tanθ)	4/8
5.5	Service brake		Electromagnetic

Driving

6.1	Drive motor rating (S2=60 min)	kw	2.5(AC)
6.2	Lift motor rating (S3=15%)	kw	3.0(DC)
6.3	Battery voltage/nominal capacity	V/Ah	24/270
6.4	Battery weight	kg	240
6.5	Steering system		EPS

Others

7.1	Battery replacement method		Hoisting
-----	----------------------------	--	----------

Note:

1. The above table is the standard model data, which will be changed according to different configurations; model upgrade and optimization will also lead to local structure and partial size changes;

2. Optional configuration and non-standard customization:

- ① The length, width and outer distance of the fork;
- ② Warp beam truck(fork and inclined plane);
- ③ Side-pull batteries, batteries of different capacities;

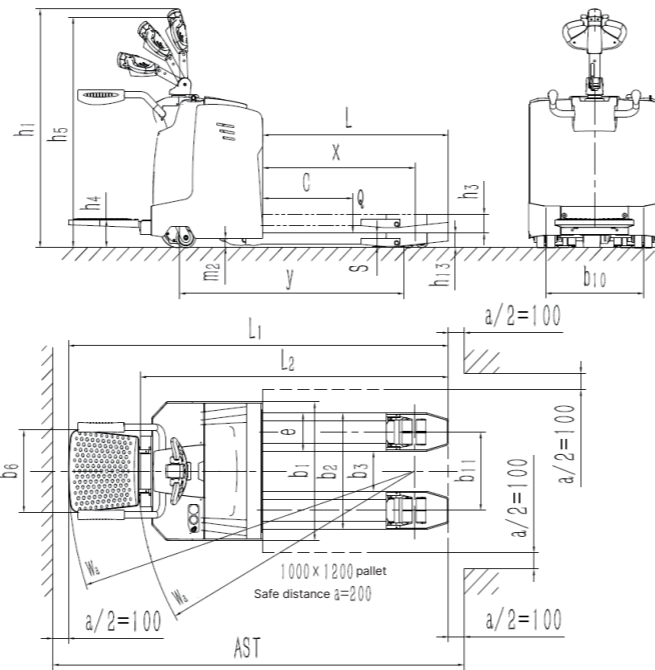

STANDARD & OPTIONAL

1150mm fork length	Customize fork length
PU wheel	Solid rubber tire for drive wheel
EPS steering	Mechanical steering
Lead acid battery	Lithium battery
With arms and platform	Side pull battery replacement
	Warning light
	Cold storage model
	Forks modified to platform
	Without arms and platform

MEB60

Electric Pallet Truck(6t)

MEB60 series, a flat pallet truck with a maximum load capacity of 6.0 tons. It is suitable for medium and long-distance large-tonnage horizontal transportation and frequent direction changes, such as loading and unloading on large trucks. Standard EPS steering makes operation easier and safer.



HUMANIZED OPERATION PANEL

The steering wheel operation makes the operation more convenient; the hydraulic valve operating handle makes the operation flexible and labor-saving; the emergency switch is used to quickly cut off the vehicle power supply in an emergency to ensure the safety of the operator; the multi-function display instrument can display the battery power and power in real time usage time

AC DRIVE SYSTEM

Maintenance-free high-power AC drive system provides reliable driving power; 350/420AH large-capacity battery provides strong endurance.

AMP WATERPROOF AND DUSTPROOF PLUG-IN

The American AMP waterproof and dustproof plug-in provides reliable protection for lines and greatly reduces electrical failures.

SMART CHARGING

Side-pull battery design facilitates battery replacement; equipped with intelligent charger, charging is convenient and fast, and can protect the battery well;

ELECTROMAGNETIC BRAKING

Electromagnetic braking, automatic braking when power is turned off, ensuring that the truck will not slip when parking.

DETAILS

- 1) Steering wheel operation makes operation more convenient.
- 2) Hydraulic valve operating lever makes operation more flexible and easier.
- 3) Emergency stop switch is used to quickly cut off the power supply in an emergency to ensure operator safety.
- 4) Multi-function instrument can real-time display of battery power and usage time;
- 5) Side pull battery design for easy battery replacement.



SPECIFICATION

Standard

1.1	Model		MEB60
1.2	Power type		Battery
1.3	Operation		Stand on
1.4	Load capacity	Q(kg)	6000
1.5	Load center distance	C(mm)	600
1.6	Front overhang	x(mm)	985/935
1.7	Wheelbase	y(mm)	1600/1545

Weights

2.1	Service weight (incl. battery)	kg	1650
2.2	Axle loading, laden rear/front	kg	2640/5010
2.3	Axle loading, unladen rear/front	kg	1270/380

Wheels

3.1	Tyre type, front/rear		PU
3.2	Tyre size, front	mm	φ85×145
3.3	Tyre size, rear	mm	φ280×135
3.4	Caster wheel	mm	φ125×50
3.5	Wheels, number front/rear(X=driven)+caster wheel		4/1X+2
3.6	Track width, rear	b10(mm)	645
3.7	Track width, front	b11(mm)	480

Dimensions

4.1	Overall height	h15	1540
4.2	Lift height	h3(mm)	100
4.3	Pedal height	h7(mm)	300
4.4	Overall length	l1(mm)	2030
4.5	Overall width	b1(mm)	1000
4.6	Fork dimensions	l/e/s(mm)	1200/125/86
4.7	Ground clearance, Min fork surface	h13(mm)	100
4.8	Fork outside spread	b5(mm)	715
4.9	Ground clearance, body	m2(mm)	60
4.10	Aisle width with pallet 1000*1200mm, C=500mm	Ast(mm)	2245
4.11	Aisle width with pallet 800*1200mm, C=600mm	Ast(mm)	2330
4.12	Turning radius	Wa(mm)	1890

Performance

5.1	Travelling speed, laden/unladen	km/h	5/6
5.2	Lift speed, laden/unladen	mm/s	18/35
5.3	Lowering speed, laden/unladen	mm/s	65/10
5.4	Gradeability, laden/unladen(S2-5min)	%(tanθ)	3/6
5.5	Service brake		Electromagnetic

Driving

6.1	Drive motor rating (S2=60 min)	kw	4(AC)
6.2	Lift motor rating (S3=15%)	kw	3.5(DC)
6.3	Battery voltage/nominal capacity	V/Ah	24/420
6.4	Battery weight	kg	335
6.5	Steering system		EPS

Others

7.1	Battery replacement type		Side pull
-----	--------------------------	--	-----------

Note:

1. The above table is the standard model data, which will be changed according to different configurations; model upgrade and optimization will also lead to local structure and partial size changes;
2. Optional configuration and non-standard customization:
 - ① The length, width and outer distance of the fork;
 - ② Warp beam truck(fork and inclined plane);
 - ③ Batteries of different capacities: 270-420AH.

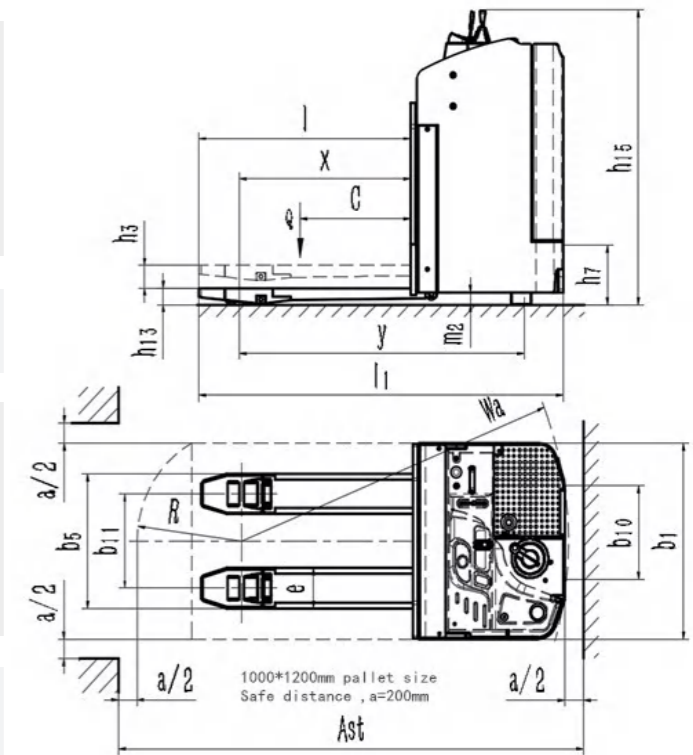

STANDARD & OPTIONAL

1200mm fork length	Customized fork length
715mm fork outside width	Customise fork outside width
EPS steering	Reversing buzzer
Side pull lead acid battery	Lithium battery
PU wheel	Warning light
	Cold storage mode
	Forks modified to platform



1994

Nearly 30 years of forklift history

600+

Employees

50+

National invention patents

72000m²

Total area

Founded in 1994, Banyitong Science & Technology Developing Co., Ltd. is a high-tech enterprise specializing in designing and manufacturing high-end electric material handling equipment. The company covers an area of 72,000 square meters with 600 employees. We are one of the first batch of national "SRDI"(Specialization, Refinement, Differentiation, Innovation)small giant enterprises in Anhui Province, with a highly qualified R&D team of over 100 engineers. We're also an industrial technology R&D center in Anhui province.

"MiMA", our product brand, is interpreted as Min. Space, Max. Performance! We aim to create more excellent value for customers through our professional products and realize more fantastic dreams together with our customers.