

V202312-EN

MiMA[®]

Min. Space Max. Performance

BANYITONG SCIENCE & TECHNOLOGY DEVELOPING CO.,LTD.

Since 1994

Electric Forklift Truck

TKA Series / TKC Series

MiMA[®]
Min Space,Max Performance



ΕΠΙΚΟΙΝΩΝΗΣΤΕ ΜΑΖΙ ΜΑΣ

PEBRO - ΑΦΟΙ ΠΕΤΡΟΓΙΑΝΝΗ
Αγίας Σοφίας, Θέση Μιλιαδίστα Ασπρόπυργος,
19300, Αττική, Ελλάδα

Mail: info@pebro.gr Τηλέφωνο: +30 2105595360



Επίσημος εκπρόσωπος της



Three-wheel counterbalanced forklift

www.mimaforklift.com

TKA10 / TKA15

3-WHEEL ELECTRIC FORKLIFT TRUCK(1.0t/1.5t)

- 1)The entire vehicle has a compact structure, flexible maneuverability, and small turning radius.
- 2)Light weight and widely used in narrow space workplaces such as floors, elevators, warehouses, supermarkets, and workshops.
- 3)It is an ideal tool for loading, unloading, and stacking in warehouses, supermarkets, and workshops



▶ Three-point structure, rear wheel steering, extremely small turning radius.

▶ The wide-view mast design is adopted to facilitate observation and improve work efficiency.

▶ Scientific ergonomically designed steering wheel with adjustable inclination and adjustable seat back and forth providing the operator with the best driving position.

▶ Using electromagnetic brakes, parking on slopes is also very safe.

▶ AC motor is maintenance-free, with speed and temperature sensors, high reliability and long life.

▶ Comes standard with automatic speed restrictions during high lifting and cornering, as well as an electric speed limiter when lifting.



DETAILS

- 1) EPS steering with a compact wheel diameter ensures effortless and efficient maneuverability.
- 2) Small size high-strength PU drive wheel with small front overhang.
- 3) A multi-way valve comes standard, offering precise control over lifting and tilting.
- 4) Wide view mast offers effortless operation and clear observation.
- 5) Comfortable seating designed to alleviate work fatigue.
- 6) Front wheel dual-drive motor, Maintenance-free double AC motors Quicker response, Stronger power, Longer service life.

SPECIFICATION

Standard

		TKA10	TKA15	TKA15F09	
1.1	Model	TKA10	TKA15	TKA15F09	
1.2	Power type	Battery	Battery	Battery	
1.3	Operation	Seated	Seated	Seated	
1.4	Load capacity	Q(kg)	1000	1500	
1.5	Load center distance	C(mm)	500	500	
1.6	Front overhang	x(mm)	168	175	
1.7	Wheelbase	y(mm)	975~990~1020	1127~1142~1172	996~1018~1060

Weights

2.1	Service weight (incl. battery)	kg	1700	1990	2250
2.2	Axle loading, laden rear/front	kg	335 /2365	390/3170	350/3400
2.3	Axle loading, unladen rear/front	kg	1045 /655	1250/750	1450/800

Wheels

3.1	Tyre type, front/rear		PU	PU	PU/Solid rubber tires
3.2	Tyre size, front	mm	φ285×100	φ285×100	φ305×140
3.3	Tyre size, rear	mm	φ230×110	φ280×135	φ280×135
3.4	Wheels, number front/rear(X=driven)+caster wheel		2 / 1X	/	2 / 1X
3.5	Track width, rear	b10(mm)	/	2 / 1X	/
3.6	Track width, front	b11(mm)	804	804	870

Dimensions

4.1	Mast tilt angle front/rear	α/β(°)	2/4	2/4	2/4
4.2	Mast retracted height	h1(mm)	1995	1995	2065
4.3	Free lift height	h2(mm)	90	90	/
4.4	Lift height	h3(mm)	3000	3000	3000
4.5	Mast extended height	h4(mm)	3530	3530	3560
4.6	Overhead guard height	h6(mm)	1965	1965	1965
4.7	Seat height	h7(mm)	930	930	930
4.8	Overall length	L1(mm)	2330	2496	2415
4.9	Body to fork surface length	L2(mm)	1410	1576	1495
4.10	Overall width	b1/b2(mm)	912	912	1010
4.11	Fork dimensions	l/e/s(mm)	920/100/35	920/100/35	920/100/35
4.12	Installation level		2A	2A	2A
4.13	Fork carriage width	b3(mm)	620	620	680
4.14	Fork outside spread	b5(mm)	220~620	220~620	220~680
4.15	Ground clearance below mast	m1(mm)	90	90	80
4.16	Ground clearance, body	m2(mm)	90	90	90
4.17	Aisle width for pallet 1000*1200mm C=500mm	Ast(mm)	2760	2925	2845
4.18	Aisle width for pallet 800*1200mm C=600mm	Ast(mm)	2870	3037	2960
4.19	Turning radius	Wa(mm)	1255	1415	1325

Performance

5.1	Travelling speed, laden/unladen	km/h	6/7	6/7	6/7
5.2	Lift speed, laden/unladen	mm/s	150/190	125/200	125/250
5.3	Lowering speed, laden/unladen	mm/s	350/250	350/250	350/300
5.4	Gradeability, laden/unladen(S2~5min)	%(tanθ)	8/10	5/10	8/10
5.5	Service brake		Hydraulic+ Electromagnetic brake	Hydraulic+ Electromagnetic brake	Hydraulic+ Electromagnetic brake

Driving

6.1	Drive motor, rating S2=60	kw	1.5	2.3	2.3
6.2	Lift motor, rating S3=15%	kw	2	3	3.5
6.3	Battery voltage/nominal capacity	V/Ah	24/300	24/350	24/480
6.4	Battery weight	kg	277	290	370
6.5	Steering system		EPS	EPS	EPS

Options

7.1	Lithium battery, voltage/rated capacity	V/Ah	24/200	24/200	24/300
-----	---	------	--------	--------	--------

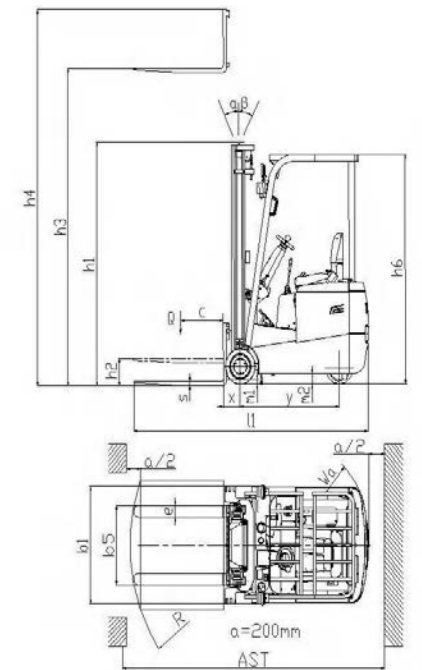

CAPACITY CHART

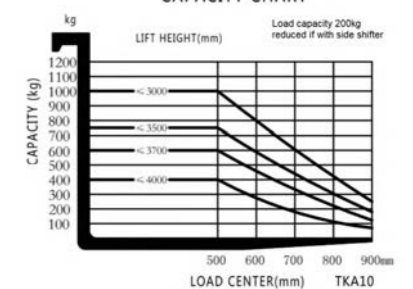

CAPACITY CHART

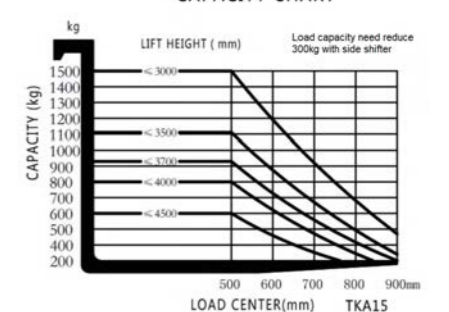

MAST SPECIFICATION

Duplex Mast

1.1	Model	TKA	10-25	10-27	10-30	10-33	10-35	10-37	10-40
1.2	Lift height	h3(mm)	2500	2700	3000	3300	3500	3700	4000
1.3	Mast extended height	h4(mm)	3030	3230	3530	3830	4030	4230	4530
1.4	Mast retracted height	h1(kg)	1745	1845	1995	2145	2245	2345	2545
1.5	Free lift height	h2(mm)	110	110	110	110	110	110	110

Duplex Mast

2.1	Model	TKA	15-25	15-27	15-30	15-33	15-35	15-37	15-40	15-45
2.2	Lift height	h3(mm)	2500	2700	3000	3300	3500	3700	4000	4500
2.3	Mast extended height	h4(mm)	3060	3260	3560	3860	4060	4260	4610	5110
2.4	Mast retracted height	h1(kg)	1815	1915	2065	2215	2315	2415	2615	2865
2.5	Free lift height	h2(mm)	/	/	/	/	/	/	/	/

Triplex Mast

3.1	Model	TKA	15-45
3.2	Lift height	h3(mm)	4500
3.3	Mast extended height	h4(mm)	5180
3.4	Mast retracted height	h1(kg)	2100
3.5	Free lift height	h2(mm)	/

Remark [1] all above mast are available with side shifter as option with the same specification

STANDARD & OPTIONAL

920mm Fork length	1070/1220mm Fork length
PU wheel	Solid rubber tire
Tri-color taillight	Blue light/warning light
Lead acid battery	Lithium battery
EPS	Closed cabin
AC Driving system	Side shifter
Duplex and Triplex mast	Cold storage (-25°)

TKC16 / TKC20

3-WHEEL ELECTRIC FORKLIFT TRUCK(1.6t/2.0t)

The MiMA TKC series is a versatile three-point counterbalance forklift with an efficient AC dual-drive system. Boasting a compact design, it allows for tighter stacking in space-constrained environments, ensuring maximum space utilization. With its advanced imported control system, it ensures stability, safety, and real-time operator updates. Ideal for warehousing and indoor material transportation tasks where space and operational efficiency are paramount.



- ▶ Three-wheel structure with rear-wheel steering provides an extremely small turning radius.
- ▶ The AC motor is maintenance-free and has a long lifespan. It's equipped with speed and temperature sensors, ensuring high reliability.
- ▶ Designed with a low mast and low overhead guard height, making it suitable for cold storage and service elevators.
- ▶ The vehicle boasts a low center of gravity, providing good stability, excellent cornering smoothness, and a comfortable driving experience.
- ▶ Features a human-computer interactive interface screen that is simple to understand.
- ▶ Equipped with an advanced imported brand controller, ensuring greater stability and safety.



Optional Lithium battery



DETAILS

- 1) With ergonomic design, the adjustable steering wheel and seat ensure the operator's optimal driving comfort.
- 2) Intelligent imported control technology ensures consistently high performance with low consumption.
- 3) Three-wheel structure, In situ rotation more flexible
- 4) Front wheel dual-drive motor, Maintenance-free double AC motors Quicker response, Stronger power, Longer service life.
- 5) Wide-view mast design ensures easy operation, better observation, and enhanced work efficiency.
- 6) Equipped with solid rubber tires for enhanced road adaptability, ideal for both indoor and outdoor use.

SPECIFICATION

Standard

1.1	Model	2TKC16	2TKC20	
1.2	Power type	Battery	Battery	
1.3	Operation	Seated	Seated	
1.4	Load capacity	Q(kg)	1600	2000
1.5	Load center distance	C(mm)	500	500
1.6	Front overhang	x(mm)	365	370
1.7	Wheelbase	y(mm)	1400	1400

Weight

2.1	Service Weight(incl/excl. battery)	kg	3290/2640	3420/2650
2.2	Axle loading, laden, front/rear	kg	4105/785	4851/579
2.3	Axle loading, unladen, front/rear	kg	1514/1776	1605/1825

Type

3.1	Tyre type, front/rear	Solid Tyre	Solid Tyre
3.2	Tyre size, front	457×152×308	457×178×308
3.3	Tyre size, rear	381×127×286	381×127×286
3.4	Wheels,number front/rear (X=driven)	2X/2	2X/2

Size

4.1	Mast tilt angle front/rear	α/β(°)	6/6	6/6
4.2	Free Lift height	h2(mm)	145	150
4.3	Lift height	h3(mm)	3300	3300
4.4	Overhead guard height	h6(mm)	2105	2105
4.5	Seat height	h7(mm)	1062	1062
4.6	Towing pin height	h10(mm)	519	519
4.7	Overall length	L1(mm)	2880	2885
4.8	Body to fork surface length	L2(mm)	1960	1965
4.9	Overall width	b1/b2(mm)	1086/1070	1120/1070
4.10	Fork dimensions	l/e/s(mm)	920/100/35	920/100/40
4.11	Installation level (ISO2328)		2A	2A
4.12	Fork carriage width	b3(mm)	970	970
4.13	Fork outside spread (max~min)	b5(mm)	930~218	930~218
4.14	Ground Clearance (Loaded, Center of Mast)	m1(mm)	105	105
4.15	Ground Clearance (Loaded, Center of Wheelbase)	m2(mm)	100	100
4.16.1	Aisle Width (1000×1200 Across Forks)	Ast(mm)	3286	3291
4.17.2	Aisle Width (800×1200 Along Forks)	Ast(mm)	3410	3415
4.18	Turning radius	Wa(mm)	1595	1595

Performance

5.1	Travelling speed, laden/unladen	km/h	15/15	14/15
5.2	Lift speed, laden/unladen	mm/s	400/550	360/550
5.3	Lowering speed, laden/unladen	mm/s	500/550	500/550
5.4	Gradeability, laden/unladen	%	20/30	18/28
5.5	Service brake		Hydraulic	Hydraulic
5.6	Parking brake		Mechanical	Mechanical

Drive

6.1	Drive motor, rating S2=60	kw	AC4.8×2	AC4.8×2
6.2	Lift motor, rating S3=15%	kw	AC12	AC12
6.3	Lead-acid battery voltage/nominal capacity (standard)	V/Ah	48/400	48/490
6.4	Lead acid battery weight (standard)	kg	650	770

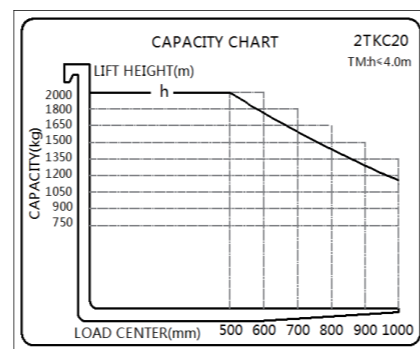
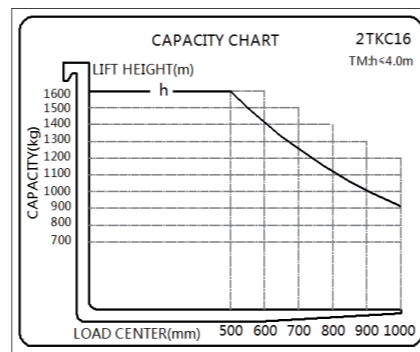
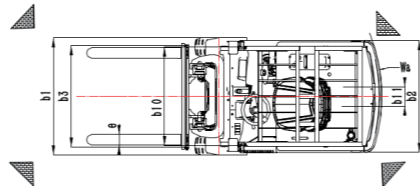
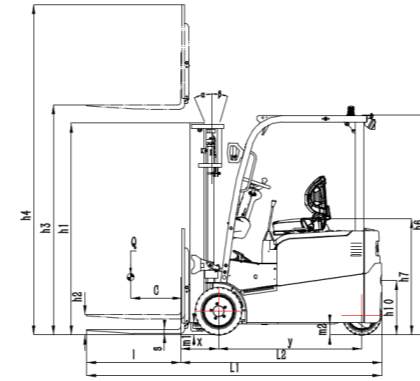

TRIPLEX FULL FREE MAST SPECIFICATION

Mast model	Lifting height	Mast retracted height	Mast extended height	Free lifting height (with standard load backrest)		Service Weight (incl.battery)		Mast tilt angle
				mm	mm	±3% kg	(°)	
Model 2TKC				16	20	16	20	all series
75T	7500	3132	8511	2156	2161	3679	3809	2/4
72T	7200	3032	8211	2056	2061	3660	3790	2/4
70T	7000	2965	8011	1989	1994	3647	3777	2/4
68T	6800	2899	7811	1923	1928	3635	3765	2/4
65T	6500	2799	7511	1823	1828	3616	3746	2/4
63T	6300	2732	7311	1756	1761	3603	3733	2/4
60T	6000	2632	7011	1656	1661	3584	3714	2/4
55T	5500	2465	6511	1489	1494	3553	3683	2/4
50T	5000	2299	6011	1323	1328	3522	3652	4/6
48T	4800	2232	5811	1256	1261	3509	3639	4/6
45T	4500	2132	5511	1156	1161	3490	3620	4/6
40T	4000	1965	5011	989	994	3458	3588	4/6
36T	3600	1832	4611	856	861	3433	3563	4/6



Optional Lithium battery